

AE025 GPS Module Antenna

Active Patch Antenna with Embedded LNA Module

Product No. AE02553GPS000

Dimensions (unit: mm)

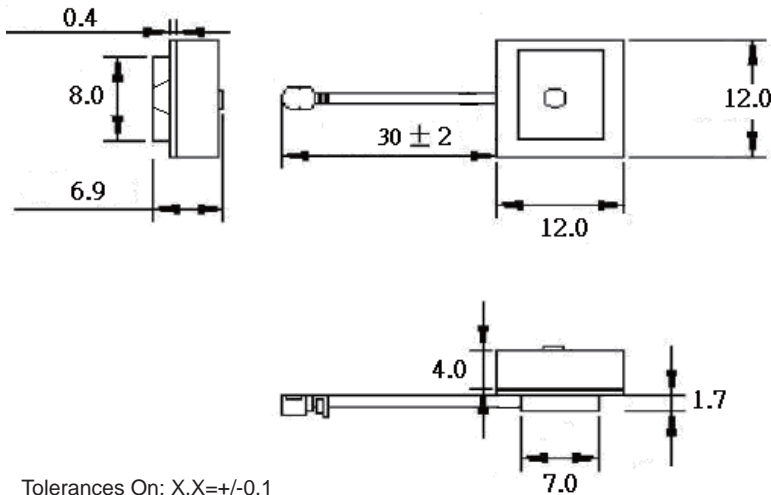

Tolerances On: X.X=±/0.1

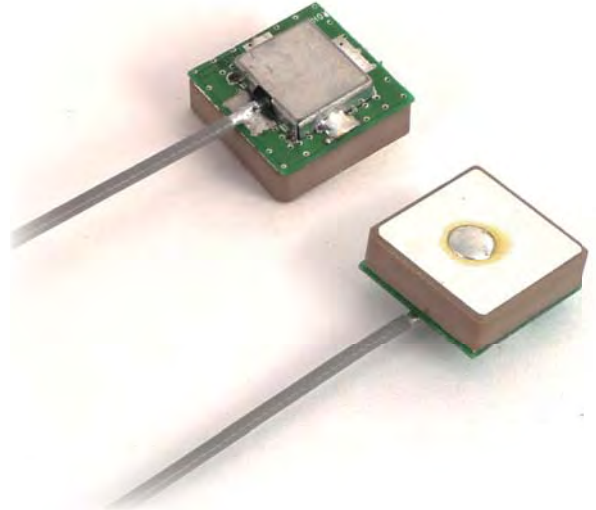

Application

- Navigation systems or position tracking systems
- Hand-held devices when GPS function is needed, e.g., PDA, Smart phone, PND.

Features

- Stable and reliable in performances
- Low temperature coefficient of frequency
- Compact size
- RoHS compliance

Physical Specification

Dimensions	12 x 12 x 6.9 mm
Weight	3.6 ± 0.3 g (typ)
Operating Condition	Temperature -40 °C ~ +85 °C
	Humidity 10 ~ 95% RH
Storage Condition	Temperature -40 °C ~ +90 °C
	Humidity 10 ~ 95% RH

Electrical Specification

Patch

Center Frequency	1575.42±1.023 MHz *when covered with a radome and measured by LNA ground plane
Bandwidth (10dB return loss)	14 MHz typ.
Gain at Zenith	-1 dBic typ.
Gain at 10° elevation	-4 dBic typ.
Polarization	R.H.C.P
Axial Ratio	3.0 dB typ
Patch size	12 x 12 x 4 mm

Filter/LNA

Center Frequency	1575.42 ± 1.023 MHz
Gain	22 dB typ at 3V
Noise Figure	0.9 dB at 3V
Filter (Out of band attenuation)	Saw filter
	40dB typ fo ± 50MHz 45dB min fo ± 100MHz (fo=1575.42MHz)
Output V.S.W.R	2.0 max
Voltage	DC = 3.0±0.5V
Current	DC = 8.5mA at 3V

All value are defined at 25±15 °C ,65±20 % RH, power handling 1 μw, air pressure 960 ±100 HPA unless otherwise noted.

Block diagram

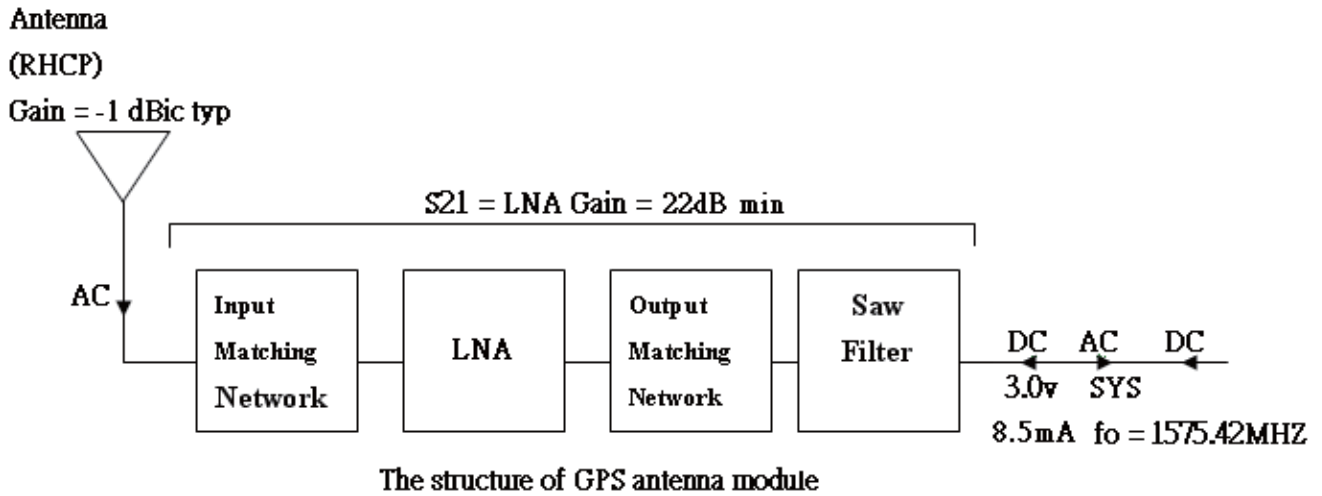

Measurement method Patch

1. Reflection Coefficient Measurement

Equipment : Network Analyzer(Agilent E5071A)(Fig.1)

Item : S_{11} Log Chart(Return loss), S_{11} Smith Chart(Impedance)



Fig.1 Network Analyzer

2. Pattern Measurement

Equipment : Anechoic Chamber(Fig. 2), Network Analyzer(Agilent E8753ES), Standard Horn

Item : Gain pattern, Axial ratio

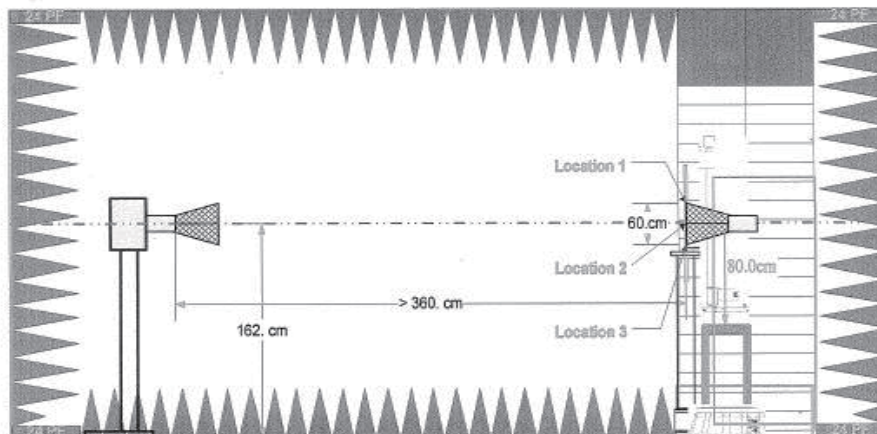

Fig.2 Quiet zoom



The plane defined in the fig3 which we measured the face of gain pattern.

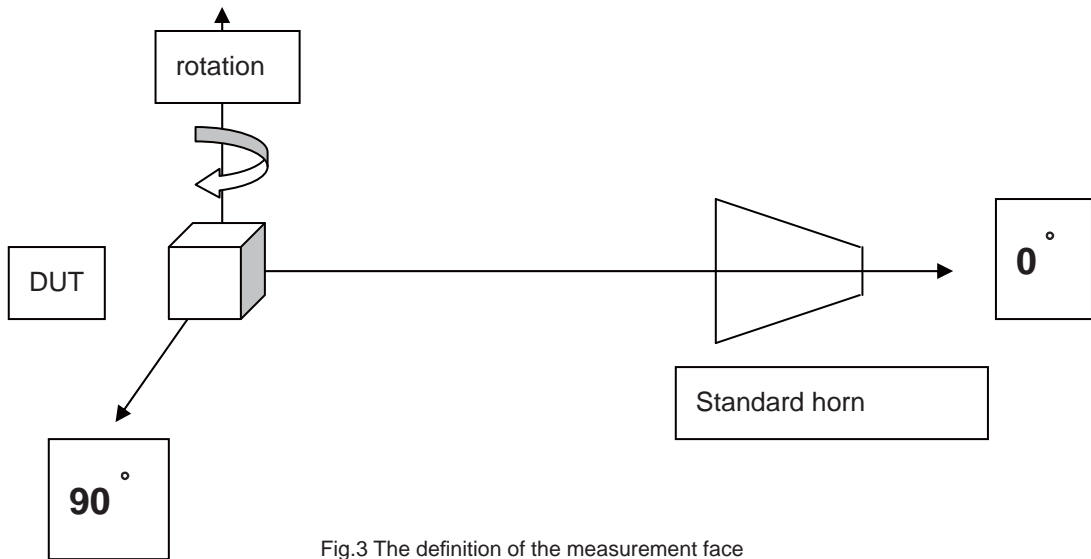

Fig.3 The definition of the measurement face

Measurement method LNA

1. Parameter Measurement

Equipment : Network Analyzer(Agilent E5071B)(fig4)

Item : S_{11} , S_{12} , S_{21} , S_{22}

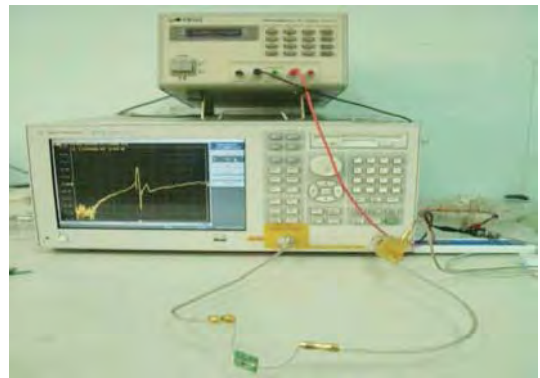

Fig.4 Network Analyzer

2. Noise Figure Measurement

Equipment : Noise meter(Agilent: E4407B-219)(fig5)

Environment : Shielding Room(fig6)

Item : N.F (Noise Figure)



Fig.5 Noise Meter

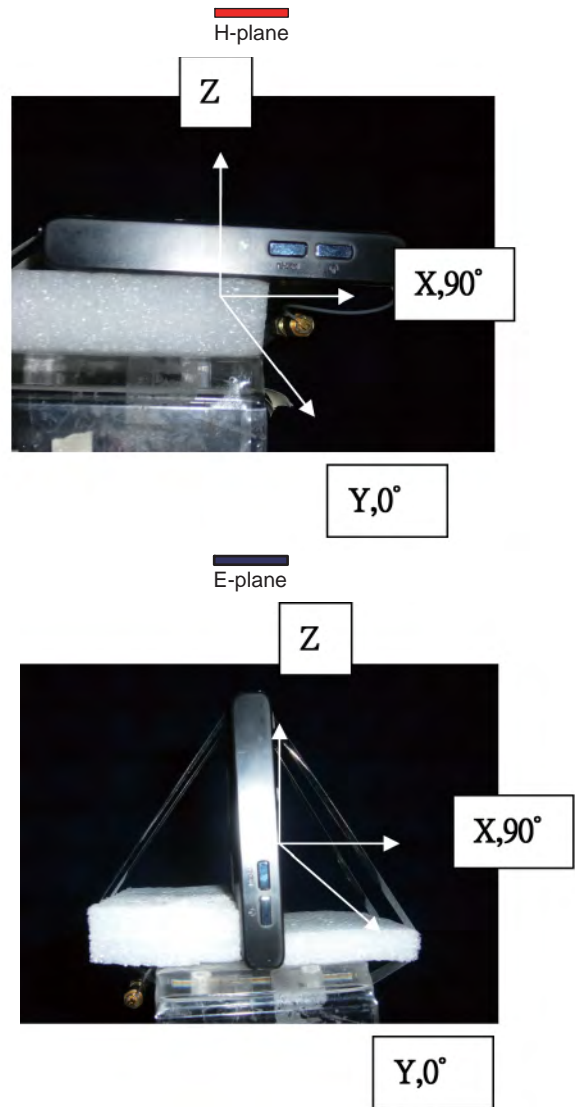
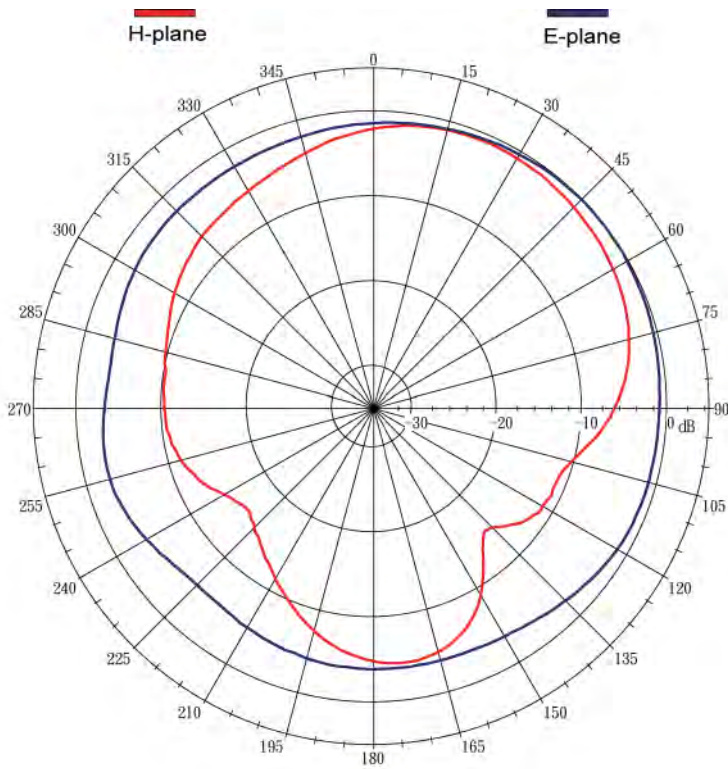

Fig.6 Shielding Room

Measured value Patch

1. Radiation Gain Pattern (exclude LNA Gain)

PS: Total Gain = Radiation Pattern (exclude LNA Gain)+ LNA Gain - cable loss(1.1dB/m)



2. S₁₁ Smith Chart (Impedance)

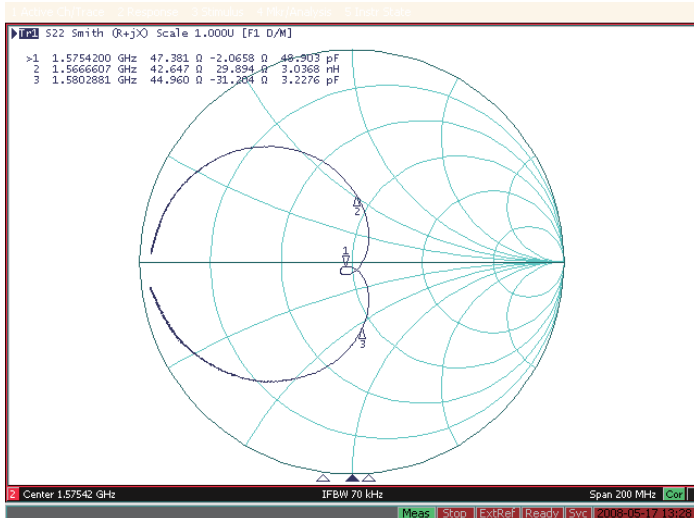

3. S₁₁ Log Chart (Return loss)

Bandwidth(S₁₁<-10dB)

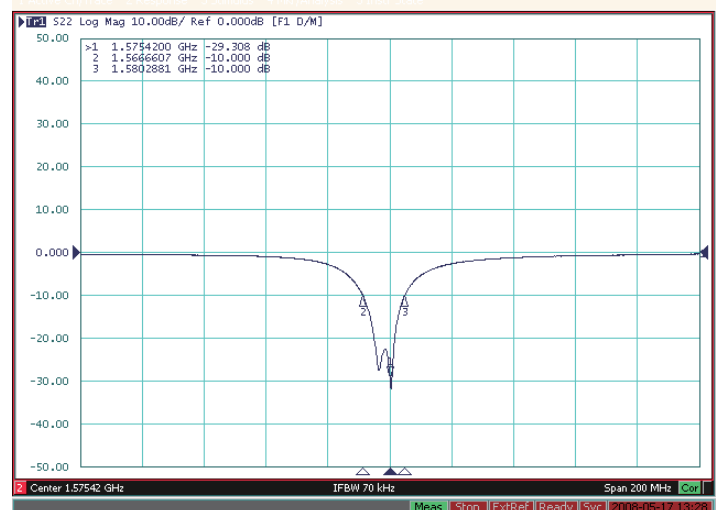

Measured value LNA

S_{11} : Network analyzer input power is -40dBm

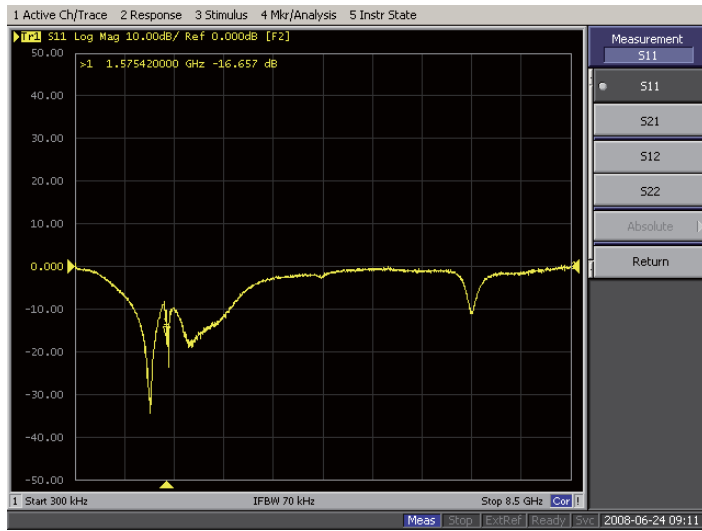

S_{21} (Gain): Network analyzer input power is -40dBm

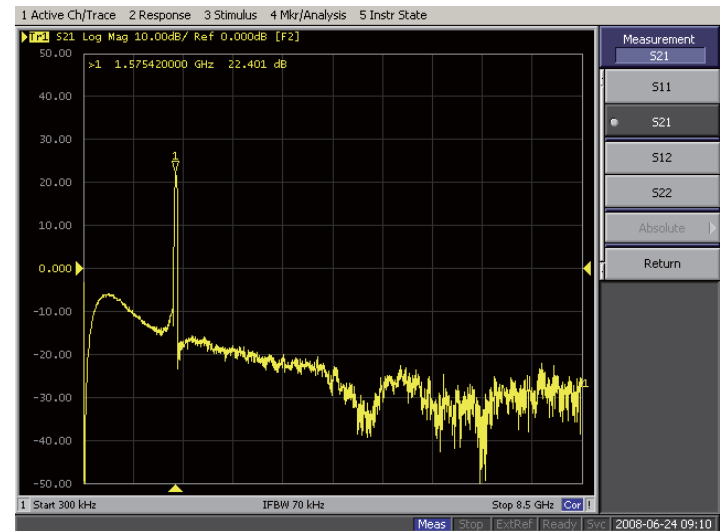

S_{12} : Network analyzer input power is -40dBm

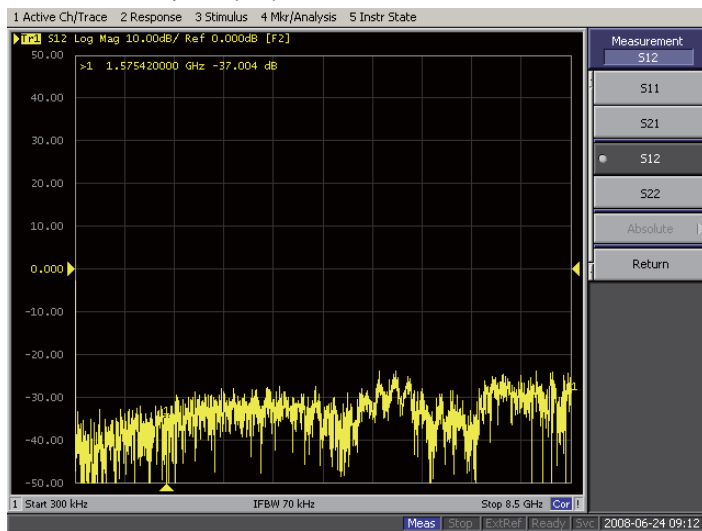

S_{22} (Gain): Network analyzer input power is -40dBm

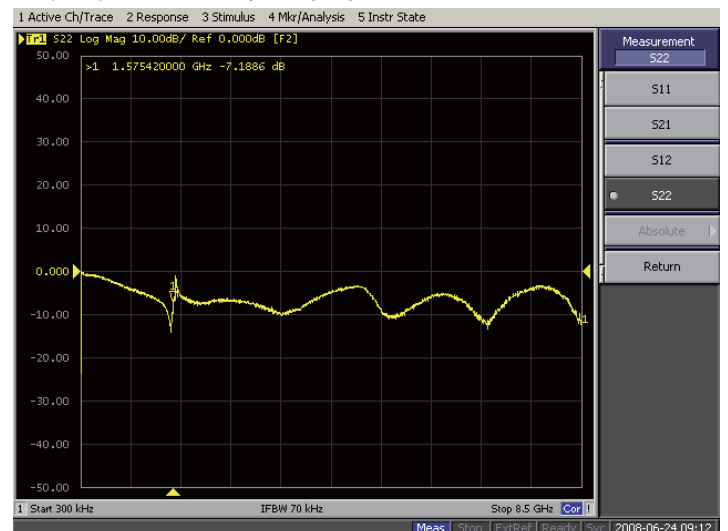

N.F (Noise Figure)

